

SUPERNOVA | HARD SKILLS

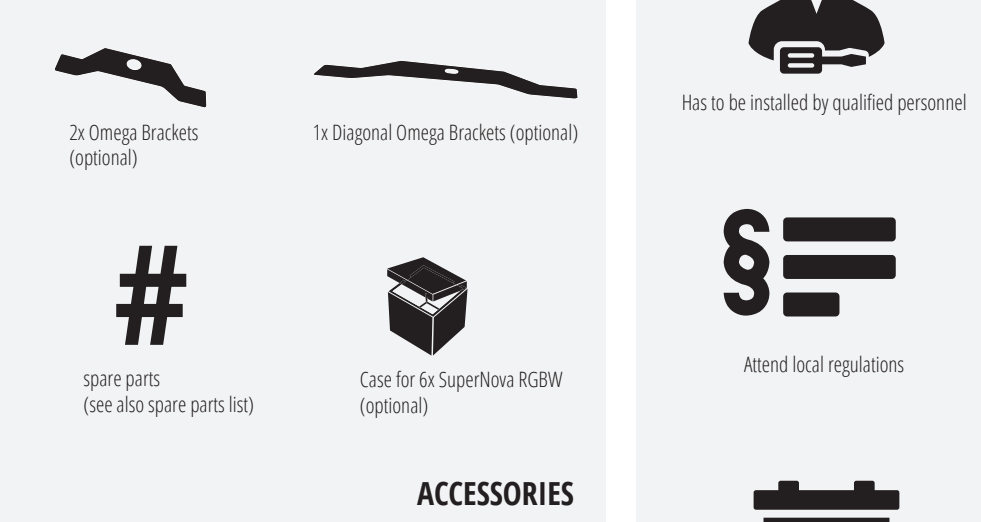

FIXTURE DIMENSIONS

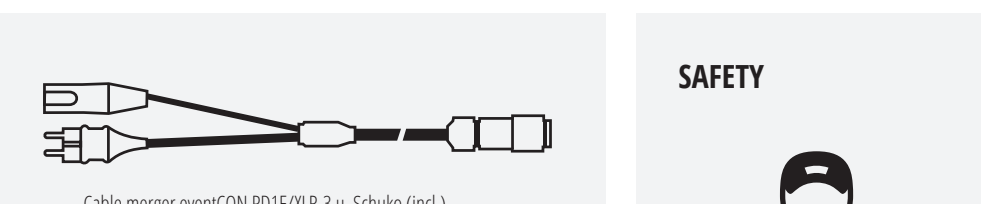
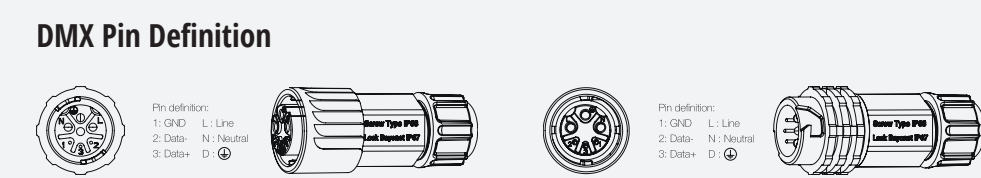
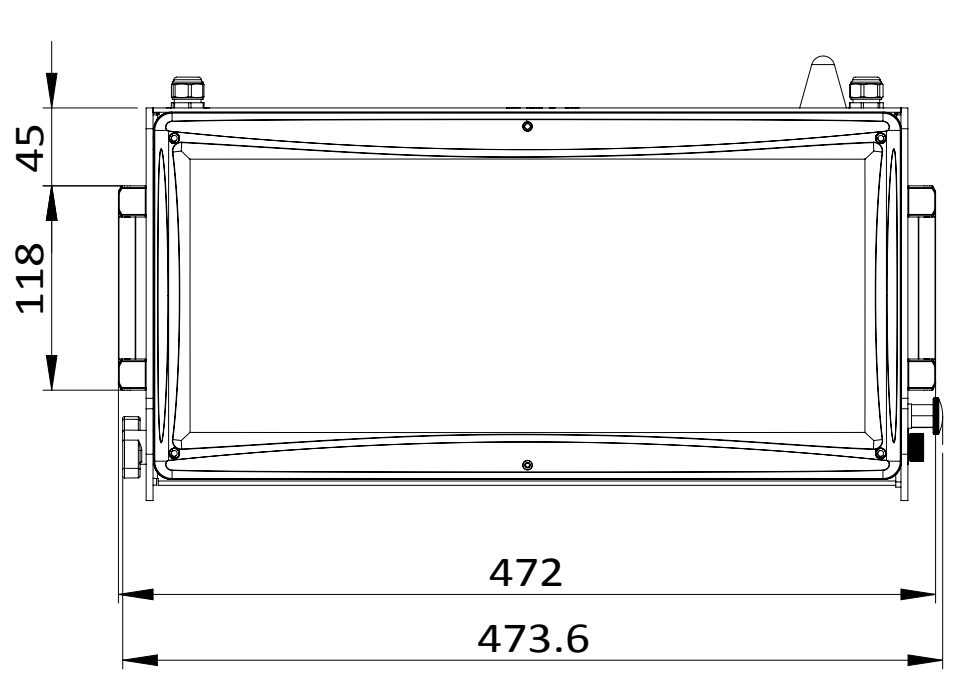
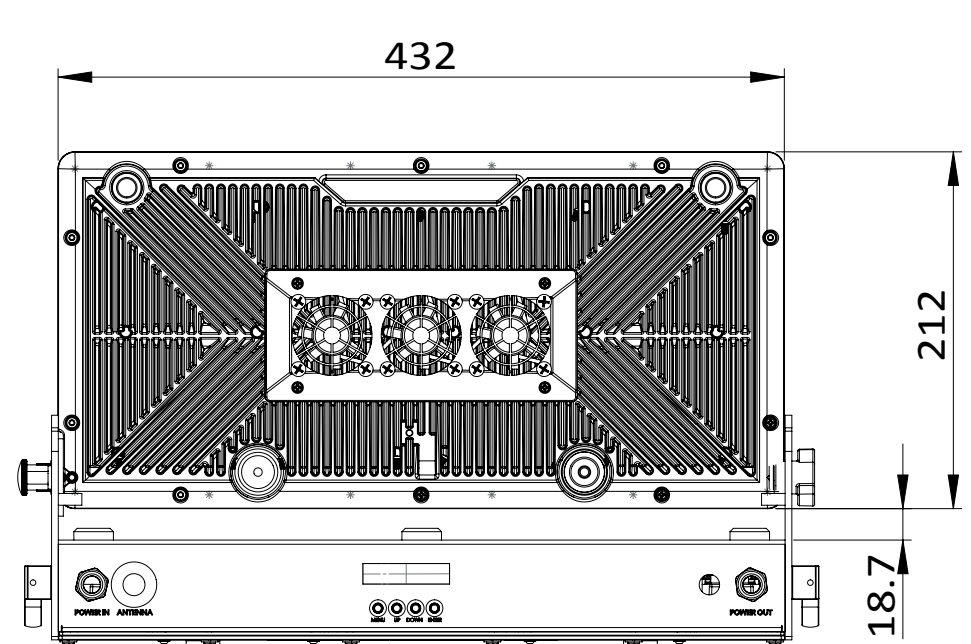
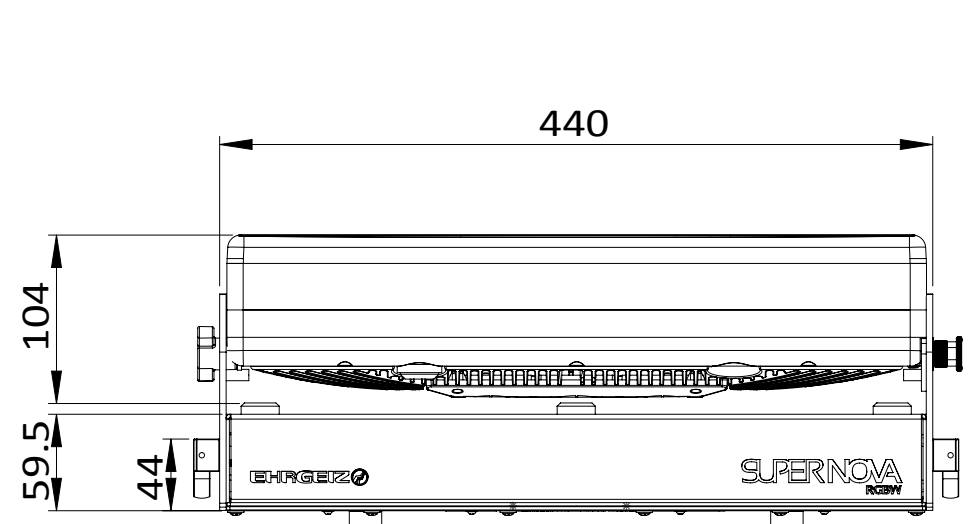

Dimensions in mm

SPECIFICATIONS

- Light source: 1372 x Osram® LED, Rated lumen output: 60.000 lm, High efficiency with typ. 96 lm/W, LED life expectancy: approx. 50.000 hours.
Optical system: Beam angle: 110°, Even flood effect.
Functions: High-resolution dimmer 0-100%, Selectable dimmer curves, Strobo with variable speed (max. 20 Hz), Selectable PWM rate, Pre-programmed random strobe & pulse effects, RGBW, 8 or 16-bit color mixing, Strobe/Color Dimming, 4 controllable LED zones, Seamless CTO, Virtual color wheel with 39 colours including whites, Remote effects with variable speed.
Thermal: Maximum ambient temperature: 45° C (113° F), intelligent fan module.
Control and programming: Setting & addressing: 2-16 characters LC display, 8-4 buttons, Protocol: LIGHT DMX 512, 4 DMX protocol modes, 3-8 addressable programs, max up to 30 steps, Stand-alone mode, Wireless DMX (Lumenra Data CDM), Firmware update via Update cable, DMX In/Out: event/DMB, Power In/Out: event/DMB.
Electrical Specification: Electronic switching power supply with auto-sensing, Input voltage: 100-240 V AC, 50/60 Hz, Max. power consumption: 700 Watt.

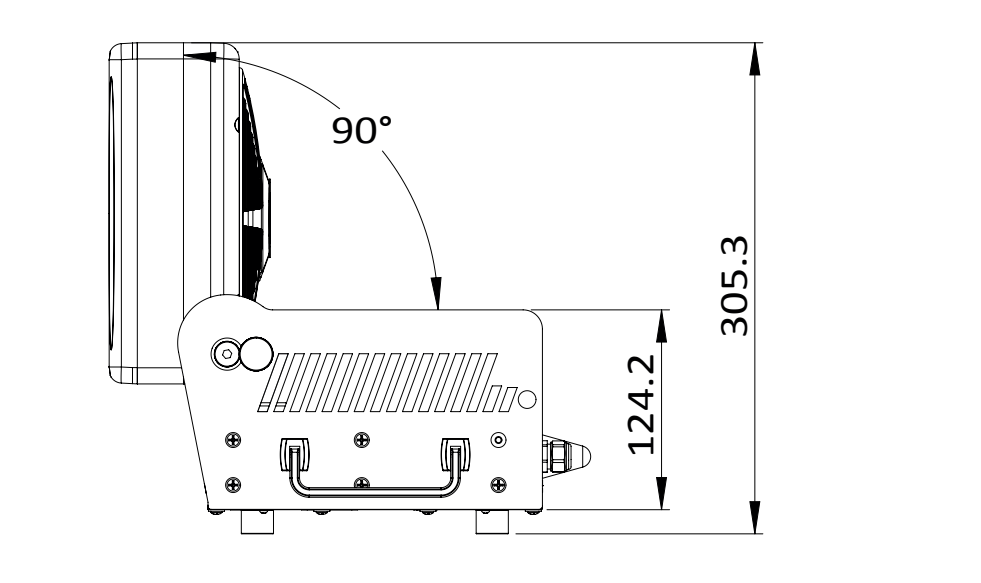
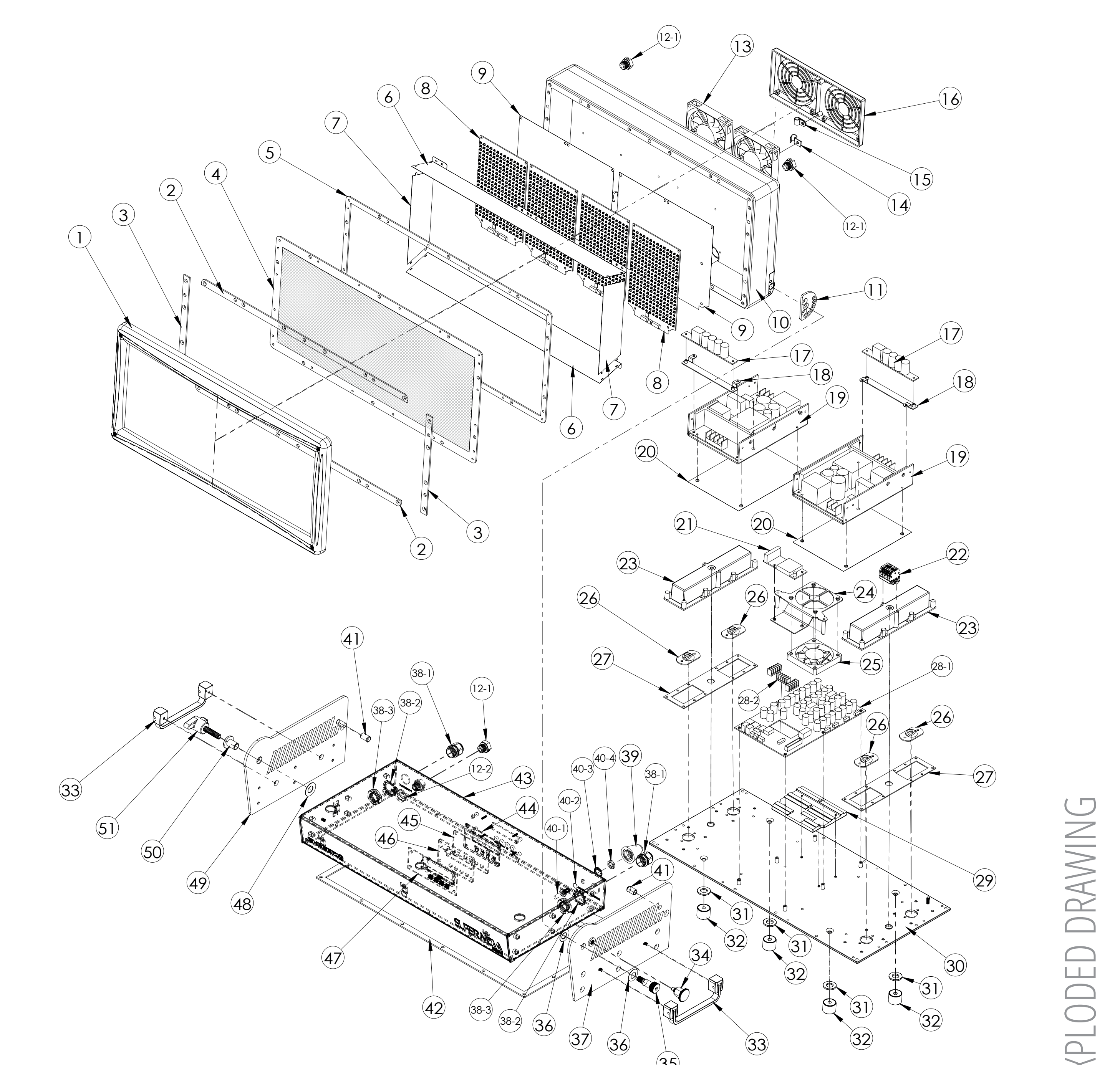

Table with 4 columns: QTY, ITEM NO., DESCRIPTION, and a list of 51 spare parts including screws, nuts, washers, and cables.



SUPERNOVA // SOFT SKILLS

MENU MAP

Menu Map table listing various settings such as DMX Address, Dimmer Speed, Cooling Mode, and DMX Modes, with checkboxes for enable/disable and brief descriptions.

DMX MODES

STANDARD MODE

Table with 2 columns: CH and FUNCTION, listing standard DMX modes like Dimmer, Shutter Duration, Shutter Flash Rate, etc.

ADVANCED MODE

Table with 2 columns: CH and FUNCTION, listing advanced DMX modes like Dimmer Rate, Shutter Duration, Shutter Flash Rate, etc.

COMPRESSED RGBW MODE

Table with 2 columns: CH and FUNCTION, listing compressed RGBW modes like Colour Wheel, Rest, White, etc.

PIXEL MAPPING MODE

Table with 2 columns: CH and FUNCTION, listing pixel mapping modes like Dimmer, Shutter Duration, Shutter Flash Rate, etc.

SHUTTER DURATION TABLE

Table with 2 columns: VALUE and FUNCTION, listing shutter duration settings from 0-5 to 255-255.

SHUTTER FLASH RATE TABLE

Table with 2 columns: VALUE and FUNCTION, listing shutter flash rate settings from 0-5 to 251-255.

SHUTTER EFFECTS TABLE

Table with 2 columns: VALUE and FUNCTION, listing shutter effects settings from 0-15 to 240-255.

SPECIAL CONTROL CHANNEL

Table with 2 columns: VALUE and FUNCTION, listing special control channel settings from 001-005 to 251-255.

CLOURWHEEL TABLE

Table with 2 columns: VALUE and FUNCTION, listing color wheel settings from 0-5 to 166-170.

SHUTTER ROTATION EFFECTS

Table with 2 columns: VALUE and FUNCTION, listing shutter rotation effects from 171-185 to 206-210.

RANDOM COLOURS

Table with 2 columns: VALUE and FUNCTION, listing random color settings from 211-225 to 251-255.

WHITE HUE

Table with 2 columns: VALUE and FUNCTION, listing white hue settings from 226-230 to 251-255.

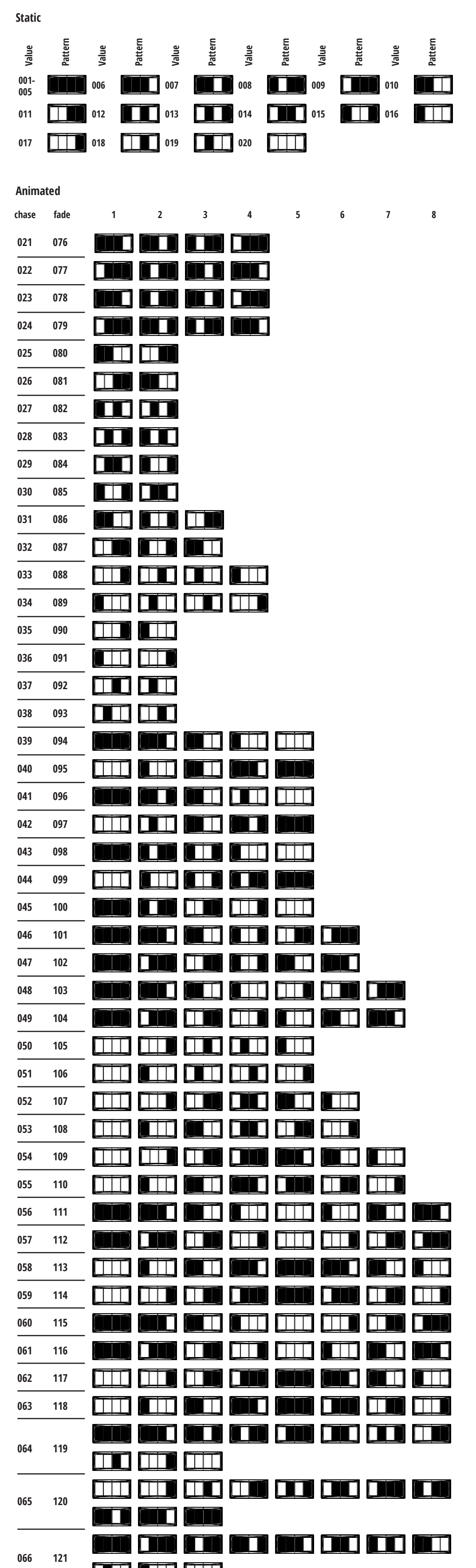

PATTERNS

Supernova RGBW Animation Pattern, DMX 000 - 020 - Static, DMX 021 - 075 - Chase Animation, DMX 076 - 130 - Fade Animation.

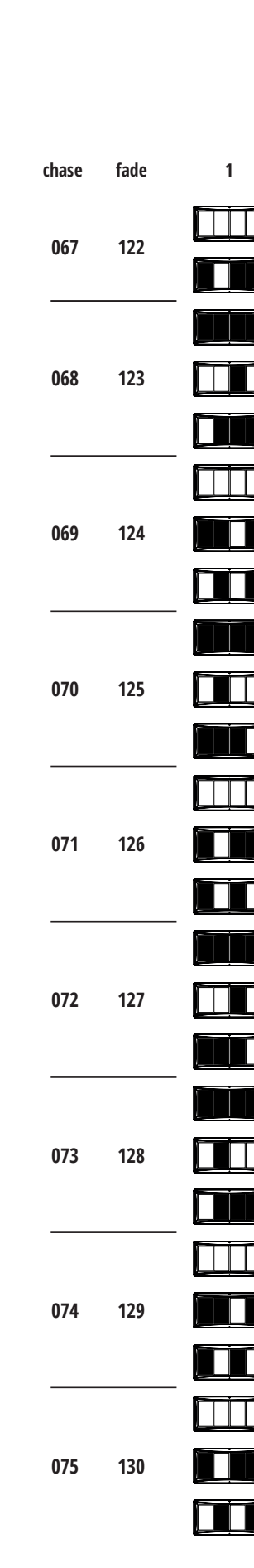

DIMMER CURVES

